

CAD FILE:

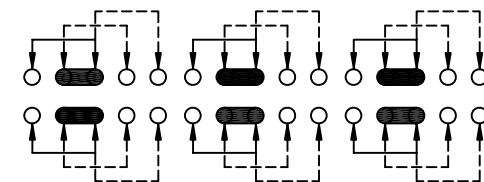

SCHEMATIC (SHORTING)

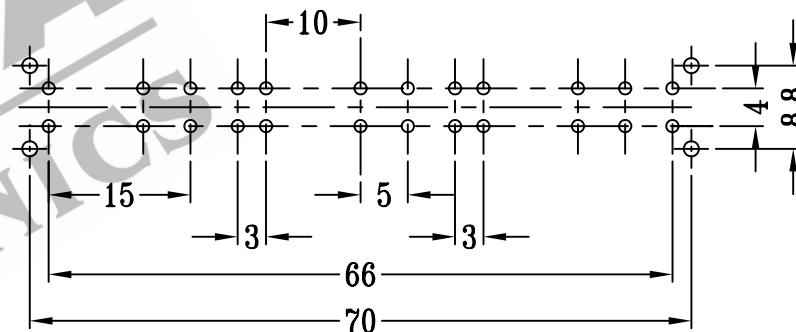
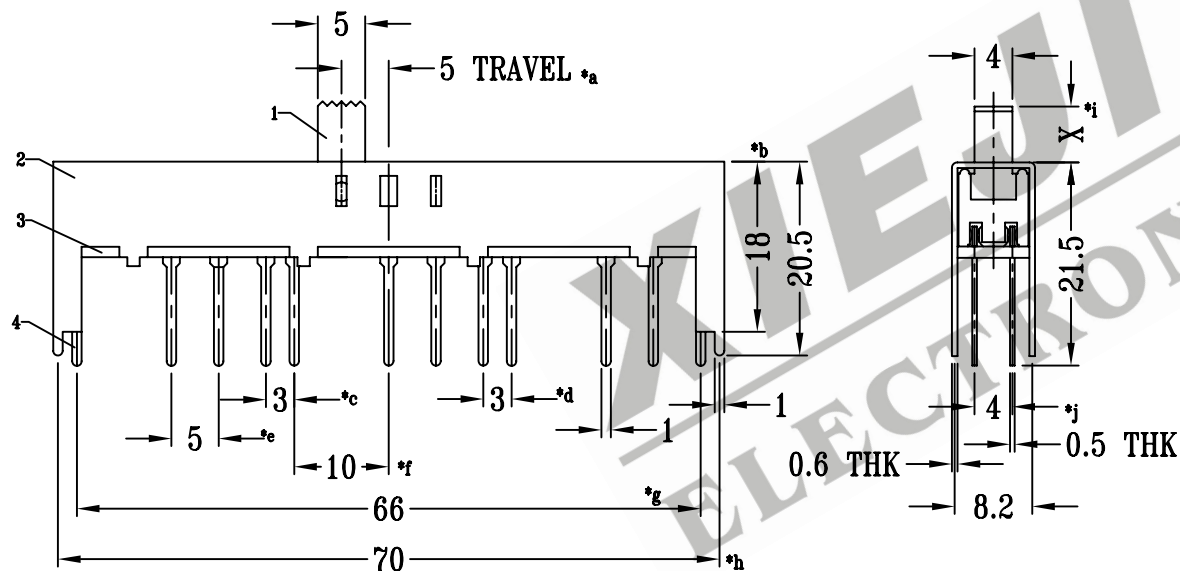
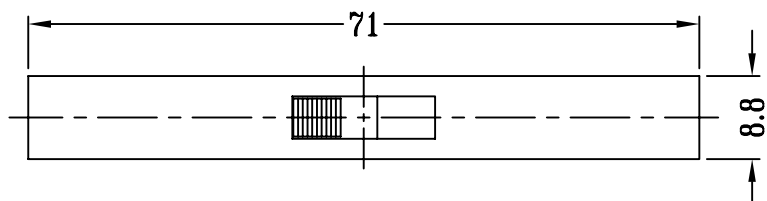

P.C.B LAYOUT

注：“\*”表示关键尺寸（10个）

NO.	PARTS	MATERIALS	Q'TY	FINISH	TOLERANCE UNLESS SPECIFIED	SHENZHEN XIEJIA ELECTRONICS CO.,LTD.					
8						ISSUE	DATE	DESCRIPTIONS OF REVISION		APPD.	
7	STEEL BALL	STEEL	1	NATURAL							
6	SPRING	STEEL WIRE	1	TEMPER	WITHIN : 1.5±0.1mm OVER : 1.5±0.2mm						
5	CONTACT CLIP	PBS STRIP	6	Ag PLATED							
4	TERMINAL	BRASS STRIP	24	Ag PLATED OVER Ni PLATED							
3	BASE	PHENOLIC RESIN	1	NATURAL							
2	FRAME	STEEL STRIP	1	Ni PLATED							
1	KNOB	POM	1	BLACK							
					TITLE : VERTICAL SLIDE SWITCH			UNIT : mm	DRWG NO.: XJ-DR-SS63J01-00		
					MODEL: SS-63J01			SCALE: 5:4	DWN.	ZHOUYU	2003-7-19
					ALL MATERIALS MUST BE COMPLIANT TO ROHS				CHK'D	FANGYING	2003-7-19
									APPD.	KANGXINAN	2003-7-19